

Booster line
ASSO III
Electric



CONTACT US

CERTIFICATION: CE UNI EN ISO 9001:2015



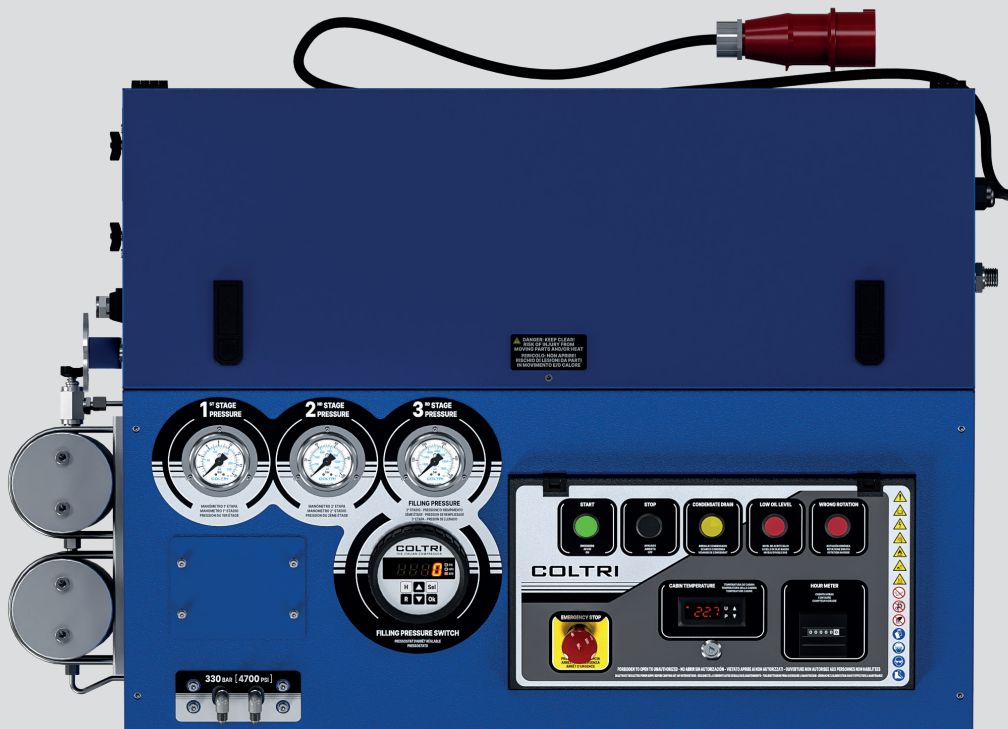

Technical data

Type of gas	Breathing air EN 12021 - Helium - Nitrogen - Argon
Intake pressure	Min. 2 bar Max. 8 bar
Nominal pressure	250 bar / 330 bar
Filling pressure	232 bar / 300 bar
Max working pressure	420 bar
Permissible ambient temperature range	-10° C ÷ +40° C
Permissible altitude	0 ÷ 1.500 m SLM
Max permissible tilt	15°
Design	Soundproof cabinet with sound absorbing
Operating voltage, standard	400 V; 50 Hz
Other operating voltage	230 V, 50 Hz / 440 V, 60 Hz / 230 V, 60 Hz
Oil	Synthetic Coltri Oil ST 755
Oil change interval	Every year / 1.000 h
Frame	Steel 1,5 mm thickness - colour RAL 5002 - Powder coating painting - scratch proof

Compressor

	ASSO III 4 KW	ASSO III 5.5 KW	ASSO III 7.5 KW
Flow rate	From 28,5 l/min to 235 l/min From 1.71 m ³ /h to 14.1 m ³ /h	From 41 l/min to 350 l/min From 2.5 m ³ /h to 21 m ³ /h	From 77 l/min to 430 l/min From 4.6 m ³ /h to 25.8 m ³ /h
Purification System	2 Hyperfilter with activated carbon		
Cooling air flow, min.	1.960 m ³ /h		
Weight	163 kg 359 lb	163 kg 359 lb	200 kg 441 lb
<small>Standard model. Weight and dimensions may vary depending on accessories.</small>			
Dimensions (W x D x H)	108 × 72 × 91 cm - 42.5 × 28.3 × 35.8 in		

Motor

	ASSO III 4 KW	ASSO III 5.5 KW	ASSO III 7.5 KW
Power	4 kW, 5.5 Hp	5,5 kW, 7.5 Hp	7,5 kW, 10 Hp
Type	Three-phase electric		
Operating voltage/frequency	400 V, 50 Hz		
<small>Different voltage / frequency available on request.</small>			
Rated current	9,7 A	12,6 A	15 A
Speed (RPM)	2.815 1/min	2.910 1/min	2.870 1/min
Protection class	IP55 (TEFC)		

Dimensions

Width 108 cm (42.5")

Depth 72 cm (28.3")

Height 91 cm (35.8")

Dry weight

ASSO III 4 KW

163 kg (359 lb)

ASSO III 5.5 KW

163 kg (359 lb)

ASSO III 7.5 KW

200 kg (441 lb)

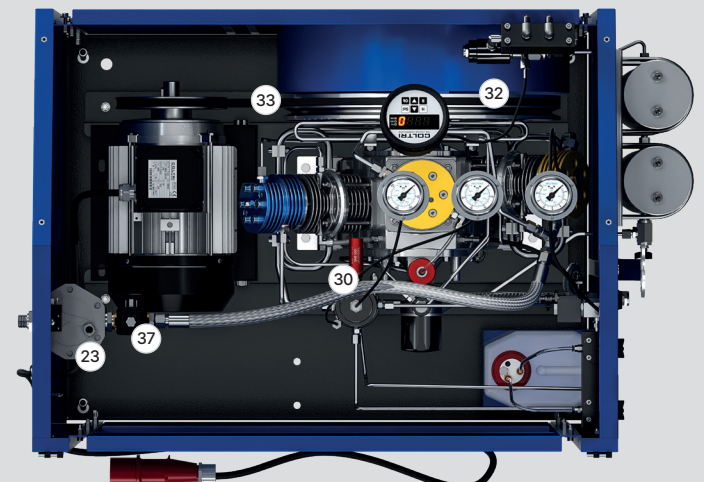
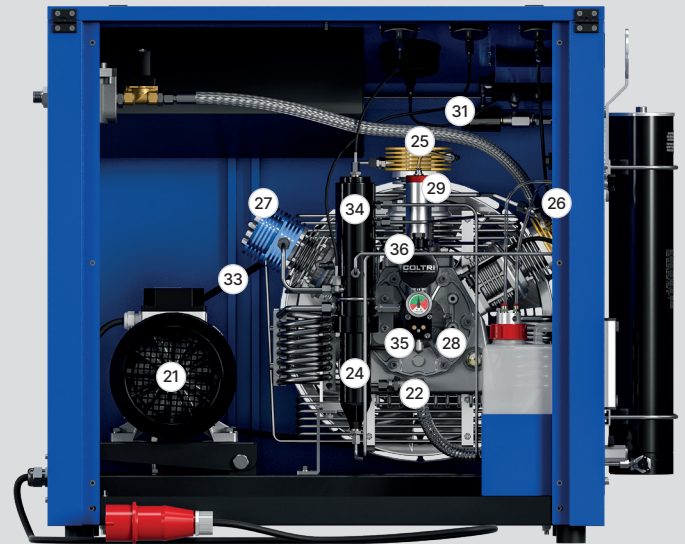
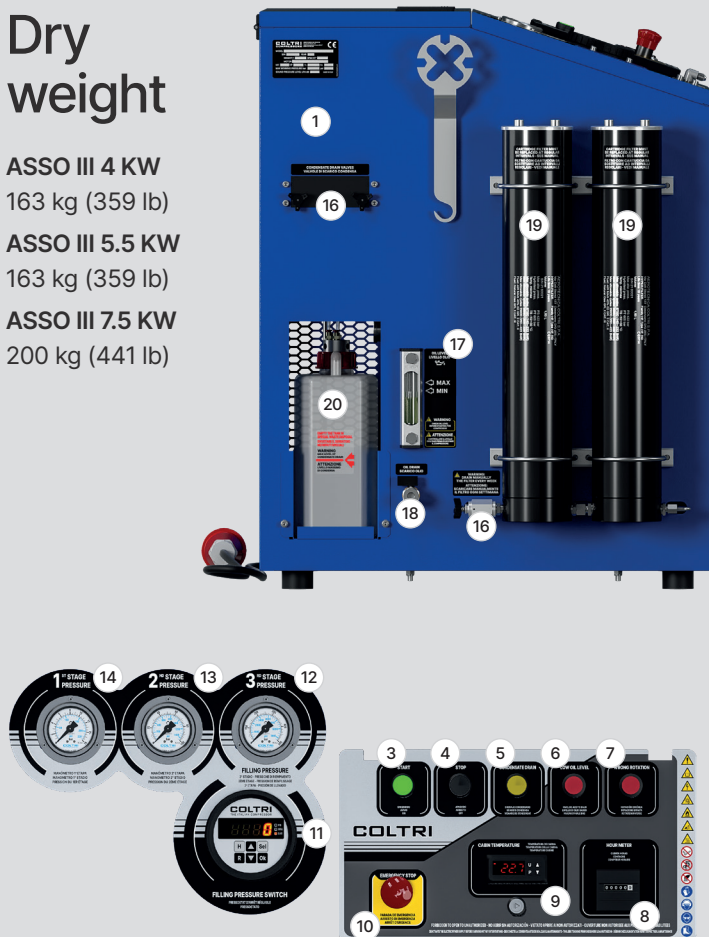

Machine parts

- | | | | | | |
|----|--|----|--|----|-------------------------|
| 1 | Frame | 13 | 2nd stage pressure gauge | 26 | 2nd stage |
| 2 | Control pannel | 14 | 1st stage pressure gauge | 27 | 3rd stage |
| 3 | ON pushbutton | 15 | Compressed gas outlet | 28 | Monobloc |
| 4 | Stop pushbutton | 16 | Condensate discharge valves | 29 | Oil filler plug |
| 5 | Condensate discharge pushbutton | 17 | Oil level | 30 | Safety valve |
| 6 | Oil level warning light | 18 | Oil discharge valves | 31 | Maintenance valve |
| 7 | Direction of rotation indicator light | 19 | Purifier filter | 32 | Cooling fan |
| 8 | Hour counter | 20 | Condensate collection can | 33 | Belt |
| 9 | Cabinet interior / cooling air temperature | 21 | Motor | 34 | HP condensate separator |
| 10 | Emergency pushbutton | 22 | Pumping unit | 35 | Oil pump |
| 11 | Automatic shutdown pressure switch | 23 | Gas filter | 36 | Oil filter |
| 12 | 3rd stage pressure gauge | 24 | LP condensate separator | 37 | Pressure switch |
| | | 25 | 1st stage gas recovery (only on Zero Loss version) | | |

GP 380

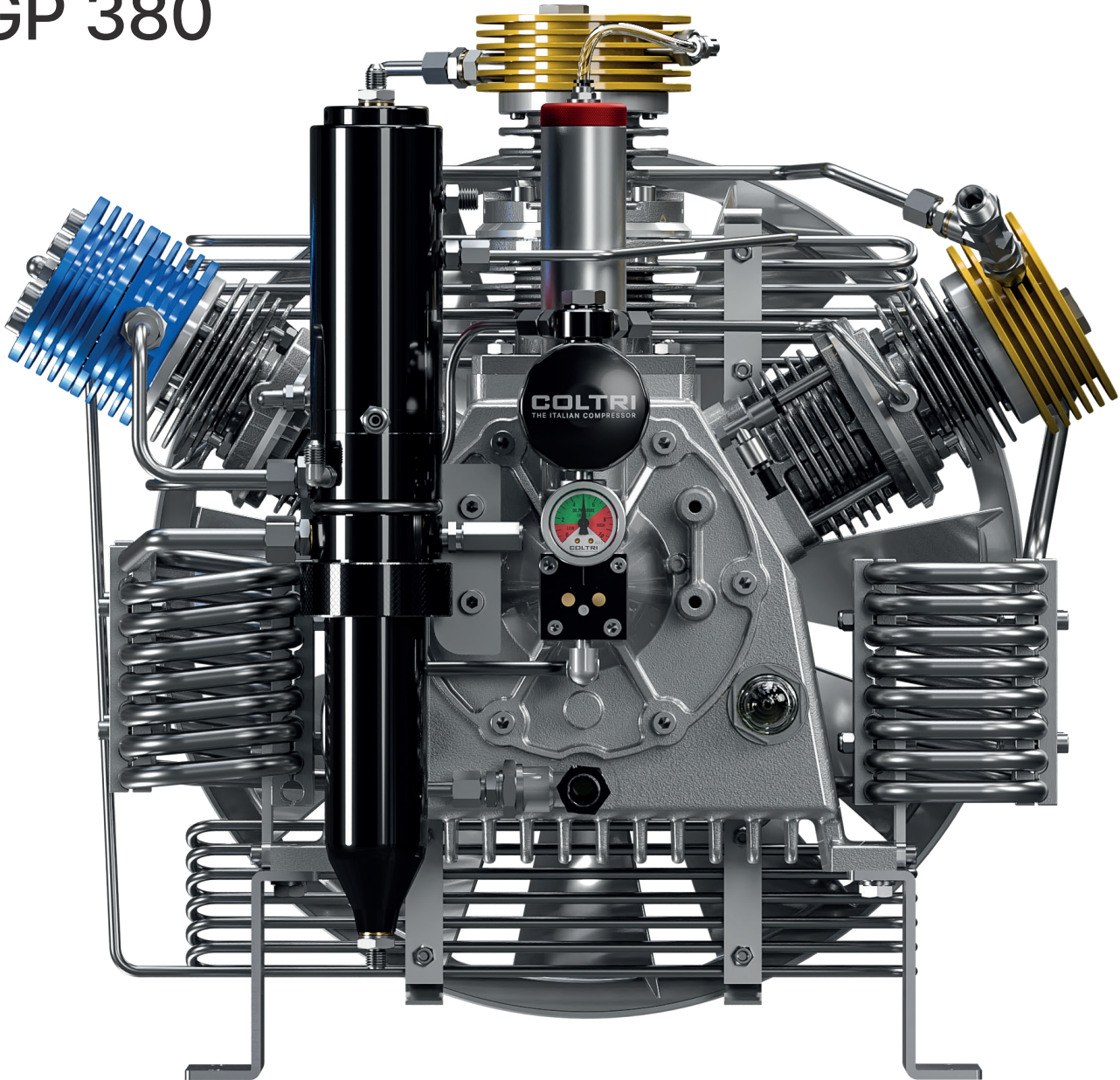

1. Forced lubrication with low pressure gear pump



2. Pipes, fittings and nuts in stainless steel AISI 316

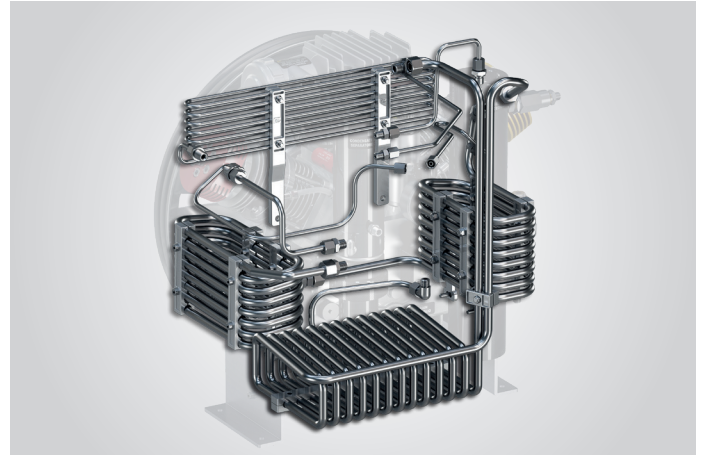

3. Pipes, fittings and nuts in stainless steel AISI 316

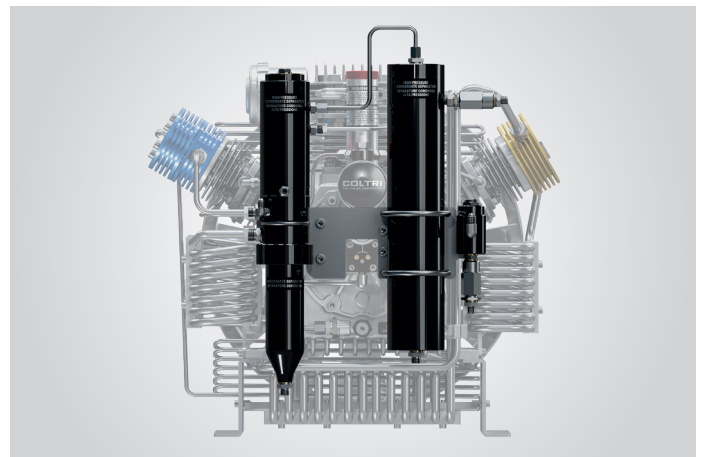

4. Synthetic oil with special formulation for HP compressors

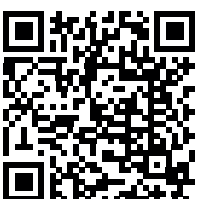

Discover more on Coltri Oil ST 755

5. Safety valves after each stage of compression

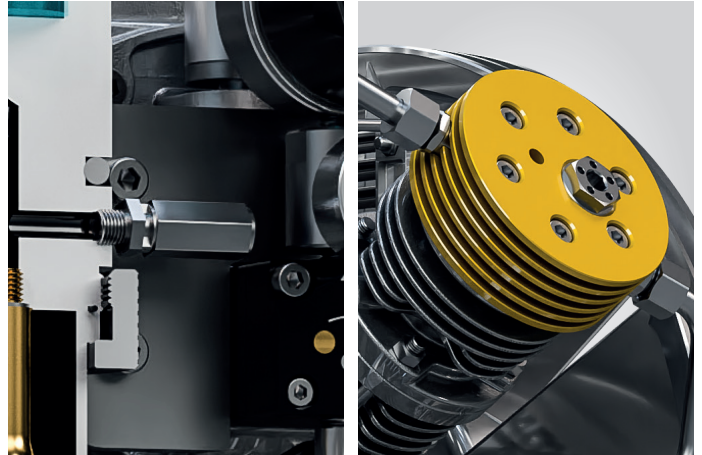

6. Die-cast aluminum cylinders with barrel coating in nicasil



7. Forged aluminum connecting rods



8. Forged steel crankshaft

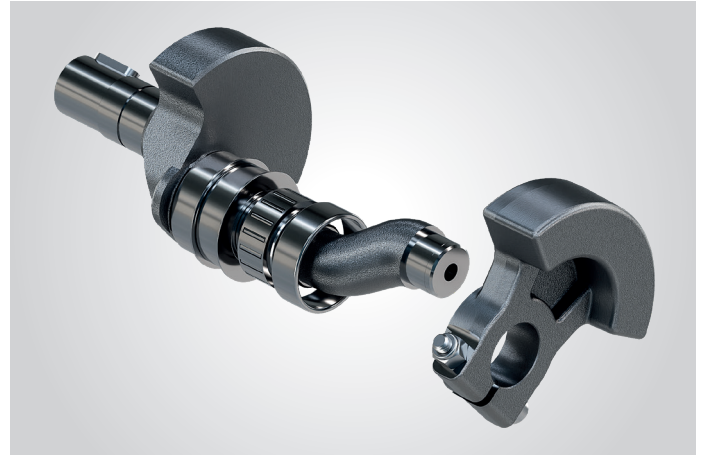

9. Stainless steel second and third stage valves

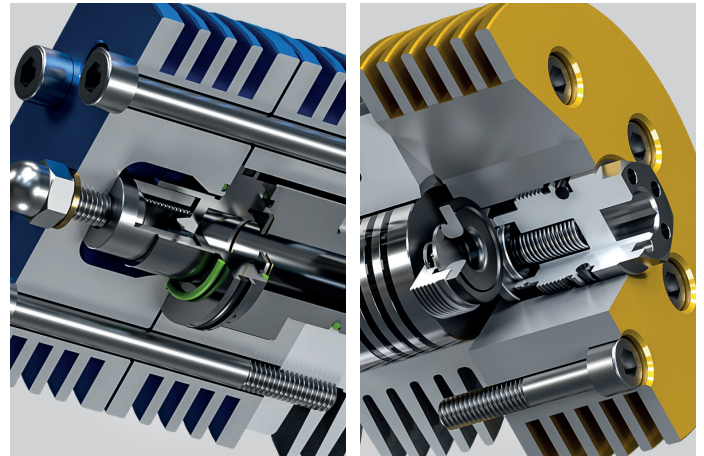

10. Roller Bearings for intensive work load



11.

Third stage in tempered steel with 5 segments in special cast iron

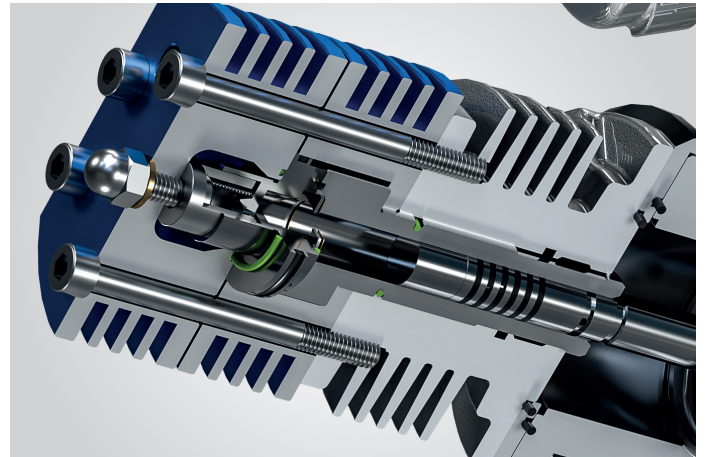

12.

Second and third stage with pushing pistons to eliminate lateral forces on the pistons

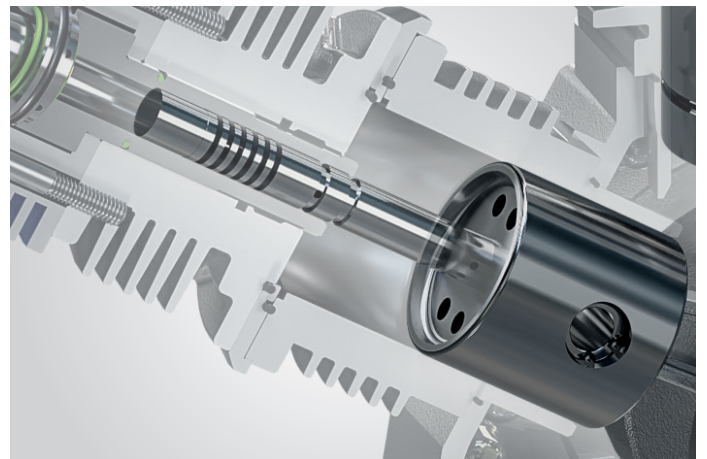

13.

First stage for gas recovery (only for Zero Loss version)

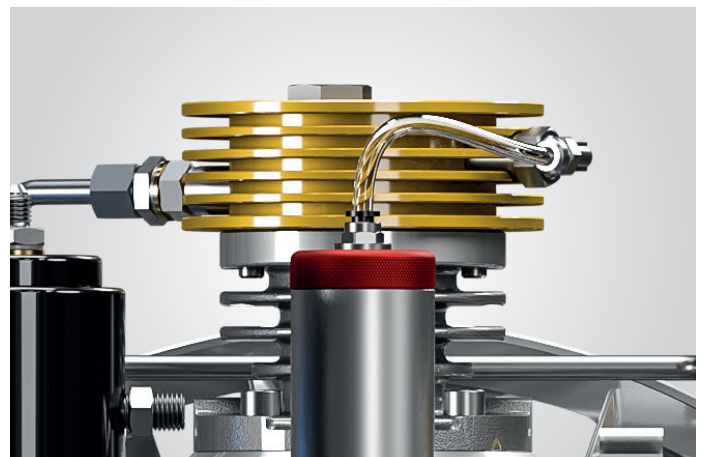

14. CE certification

COLTRI COMPRESSORS		AEROTECNICA COLTRI S.P.A. Via dei Colli Storici, 177, 25015 Desenzano del Garda (BS), Italia		CE
MODEL	ASSO III			
S/N	YEAR	WEIGHT	KG	LB
<input type="text"/>	<input type="text"/>	<input type="text"/>	<input type="text"/>	<input type="text"/>
<input type="text"/>	MOTOR			
KW	VOLT	HZ	RPM	PUMPING GROUP
<input type="text"/>	<input type="text"/>	<input type="text"/>	<input type="text"/>	<input type="text"/>
MAX WORKING PRESSURE BAR		PSI		
<input type="text"/>		<input type="text"/>		
SOUND PRESSURE LEVEL LPA dB				MADE IN ITALY
<input type="text"/>				

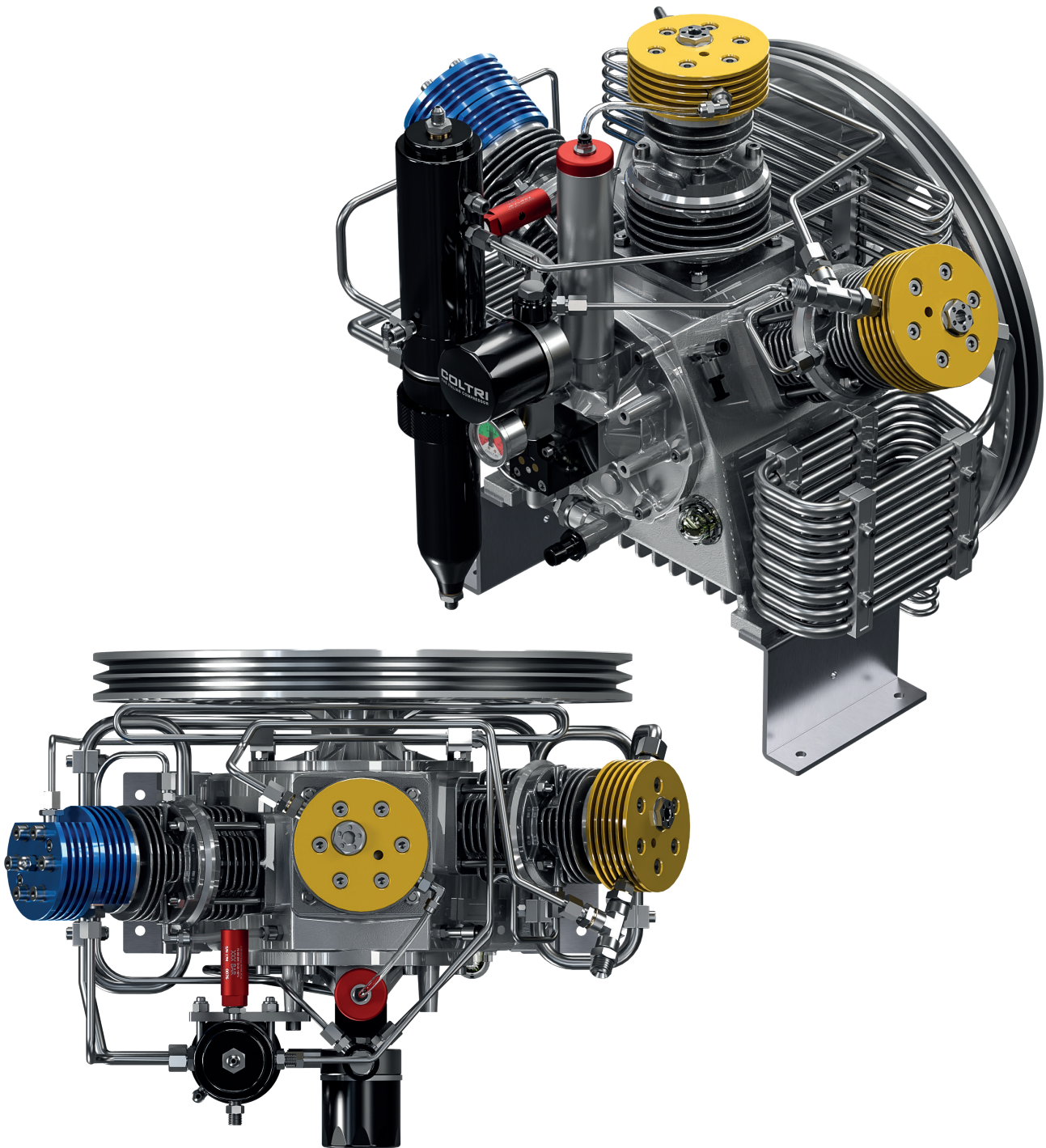

Compressor block

	ASSO III 4 KW	ASSO III 5.5 KW	ASSO III 7.5 KW
Intake pressure	2 bar - 8 bar		
Flow rate	From 28,5 l/min to 235 l/min From 1.71 m ³ /h to 14.1 m ³ /h	From 41 l/min to 350 l/min From 2.5 m ³ /h to 21 m ³ /h	From 77 l/min to 430 l/min From 4.6 m ³ /h to 25.8 m ³ /h
Speed RPM	1.200 1/min	1.400 1/min	1.400 1/min
Number of stages	2 + 1 service (Zero Loss)		
Number of cylinders	2 + 1 service (Zero Loss)		
Cylinder bore 2nd stage	38 mm		
Cylinder bore 3rd stage	15 mm		
Stroke	50 mm		
Direction of rotation (from flywheel side)	Left - counter clockwise		
Drive type	V-belt A type		
Amount of oil	1,8 liters		

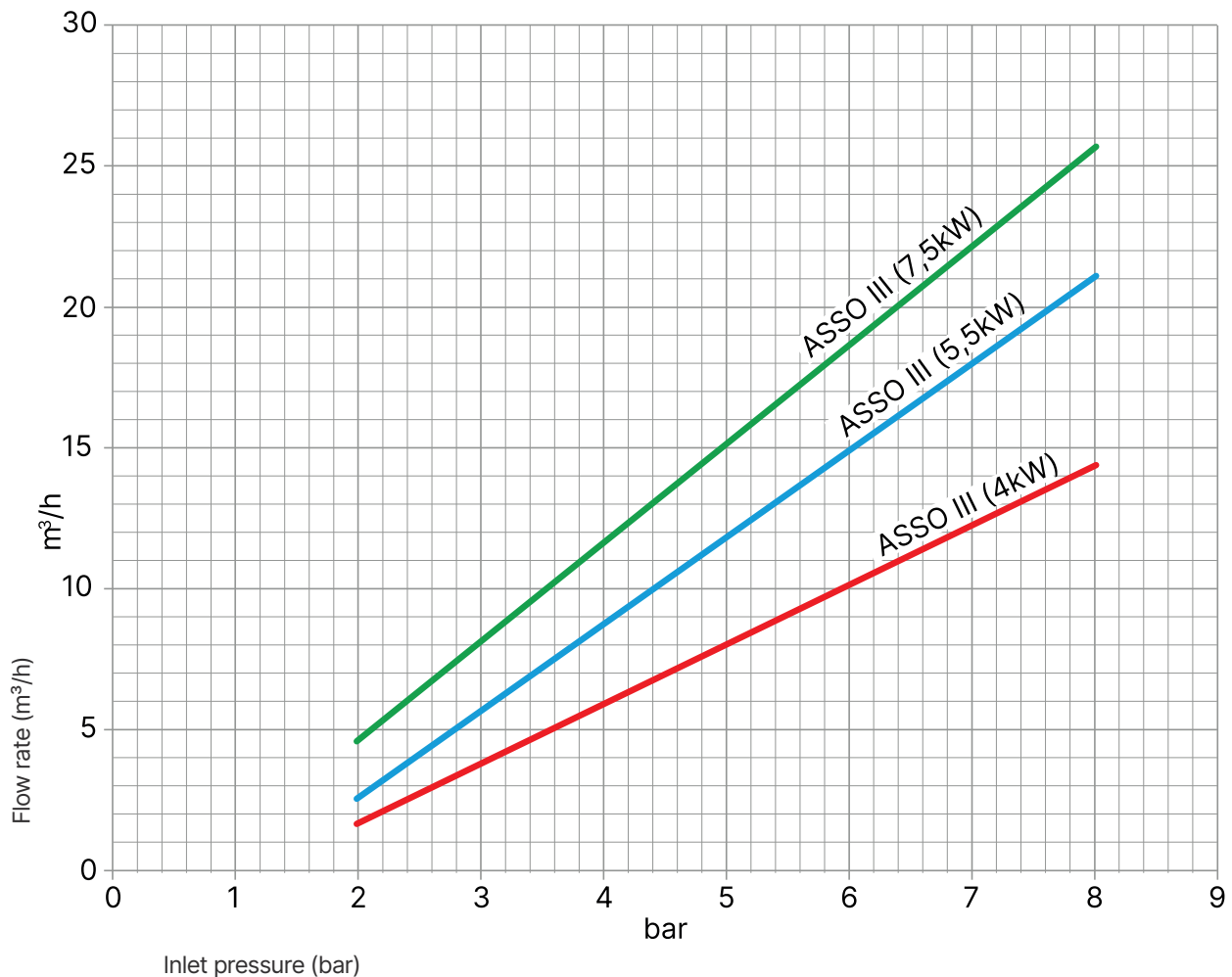

Standard equipment

Purification system HYPERFILTER

DOUBLE HYPERFILTER regenerable or disposable cartridge



Purification system

Operating pressure (Standard)

Operating pressure max. (PS)

Processable air capacity

(air inlet temperature in the filter 20° C at 300 bar)¹

Hyperfilter x 2

250 bar / 330 bar / 360 bar

420 bar

3.050 m³

¹ When using a filter cartridge without HOPCALITE CO CATALYST.

When using a cartridge with CO-removal, the processable air capacity is reduced by ca. 20%.

Separator system

- Interstage separator in forged and anodized aluminum.
- Final separator for removal of oil/water condensate
- Final safety valve, mounted on the separator housing
- Pressure maintenance valve / non-return valve
- Automatic condensate drain

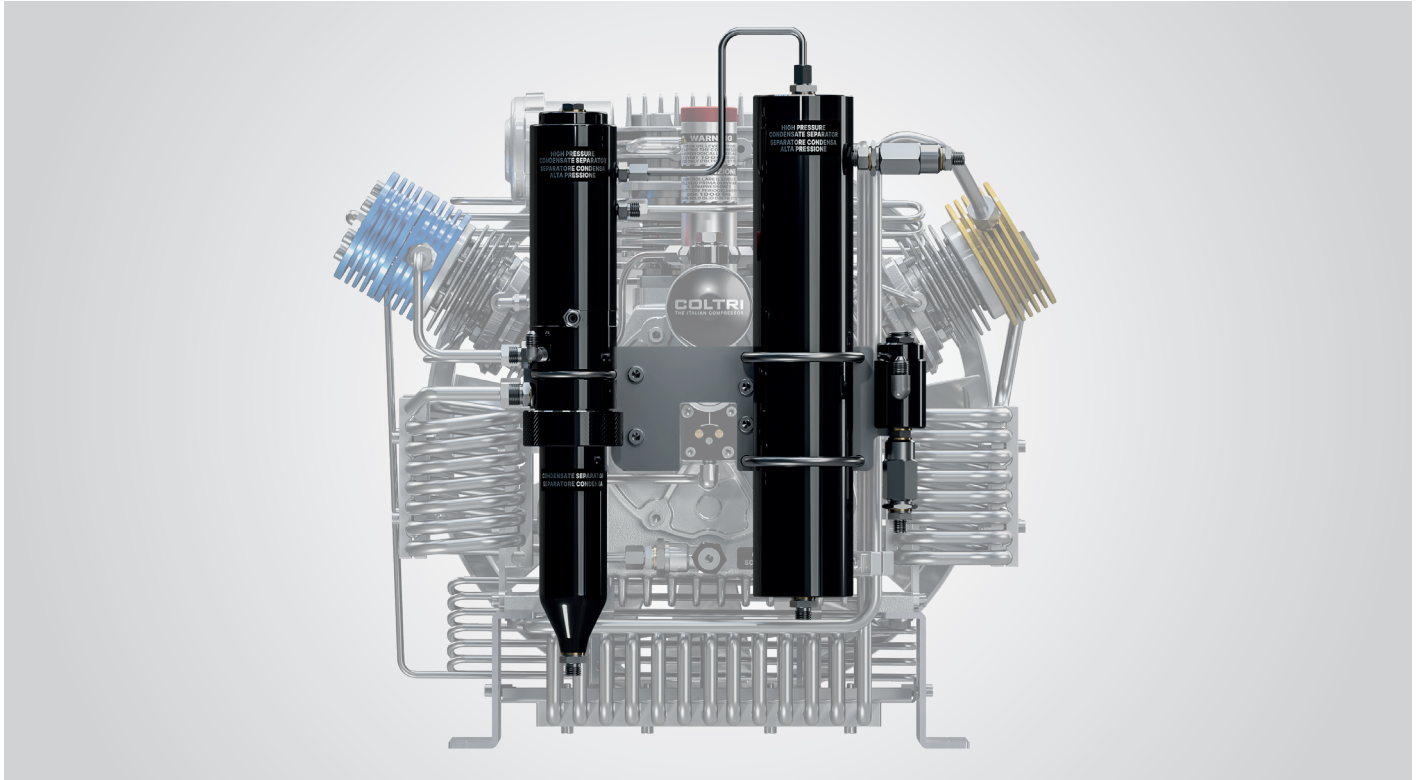

Contamination	Maximum content as per DIN EN 12021:2014	Air quality*
H ₂ O	25 mg/m ³	≤ 10 mg/m ³
CO	5 ppm(v)	≤ 4
CO ₂	500 ppm(v)	≤ 500
Oil	0,5 mg/m ³	≤ 0,5 mg/m ³

* Measured at our facility using ASCO HORA 160 ANALYZER.

1 Only with special filter cartridge with HOPCALITE CO CATALYST. and up to a maximum concentration of 25 ppm CO in intake air.

The compressed clean breathing air then contains a maximum of 5 ppm CO.

2 The level of CO₂ in the intake air must not exceed the maximum level of CO₂ as per EN 12021:2014

3 Reported values exceed ISO 8573-1 standards.

Filling connections

2 Filling connection to choose from: DRV DIN 232 bar and DRV DIN 300 bar.



Filling connection DRV DIN 232 bar
COD. DRV232

Filling connection DRV DIN 300 bar
COD. DRV300

Filling device	DRV DIN 232	DRV DIN 300
Nominal pressure (PN)	250 bar	330 bar
Valve design	Filling valve with integrated ventilation, with cylinder connector G 5/8" according to EN 144-2 and 477 PN232	Filling valve with integrated ventilation, with cylinder connector G 5/8" according to EN 144-2 and 477 PN232

Filling hose

1200 mm stainless steel fittings - max working pressure 420 bar



Electronic pressure switch

The instrument allows to visualize the pressure expressed in bar, psi or MPa.

Through the programming buttons it allows to set the intervention pressure of the relay contact (SPDT) and hysteresis. The settings are protected by passwords at 3 levels: manufacturer, customer and end user. The instrument also has the function of hours counter and no. of cycles of separator intervention, ensuring a general improvement of the operation of the recharge station over time and the longevity of its filters.



According to EN 10204 Type 2.1

N.	Caratteristiche / Characteristics	Valori richiesti / requested values	Tolleranze / Tolerances	Strumento di controllo / Test equipment	Esito verifiche / Test Result
1	Setpoint alarm	300 bar	err.max 1,5% vfs	Elect. load 16V/10mA max	OK
2	Setpoint hysteresis	10 bar	err.max 1,5% vfs	Elect. load 16V/10mA max	OK
3	Range	0 - 400 bar	err.max 1,5% vfs	Pressure gauge cl. 0,25% vfs	OK
4	Process connection	G1/4"	Tab ISO228	Ring ISO228	OK

Compressor control and automatic condensate drain system

- ON/OFF switch with motor protection switch.
- Optional: autostart at 60 bar hysteresis.
- Transformer.
- Pressure switch stops compressor at final pressure.
- Drainage of all separators between the individual stages and also of the final separator during compressor operation (standard drain interval every 15 minutes for a period of 6 seconds).
- Timer for automatic condensate drainage device.
- Integrated vacuum start-up (automatic drain when the unit is switched off).
- Condensate collection tank 5 liters, with silencer; capacity approx. 3 liters, for environmentally friendly disposal of condensate.
- Interstage pressure gauges display the operating pressure for the individual compression stages. This pressure information allows you to check the tightness of the valves (inlet and outlet) of each stage and quickly identify potential sources of failure.

The interstage pressure gauges are mounted in the compressor frame.

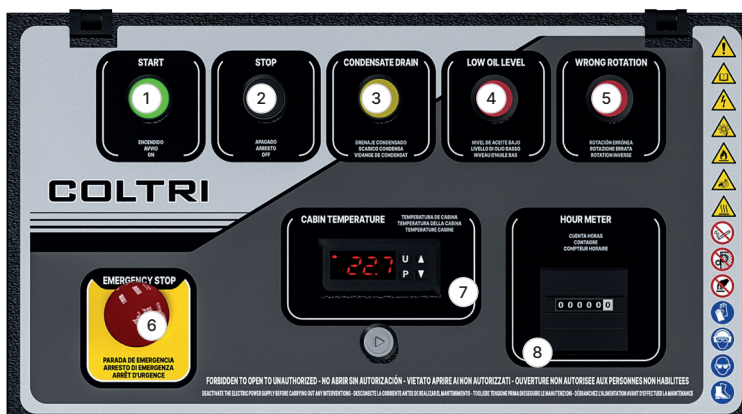

- 1 Power button
- 2 Stop button
- 3 Condensate drain button
- 4 Oil level warning light
- 5 Wrong direction indicator light
- 6 Emergency button
- 7 Inside temperature cabin/cooled air
- 8 Operating hour meter

Interstage pressure gauges

The function of the interstage pressure gauges is to show the operating pressure of the individual compression levels. This information is indispensable because it allows to quickly recognize a possible error by checking the tightness of the respective level valves (inlet and outlet). The interstage pressure gauges are mounted on the control panel of the compressor.

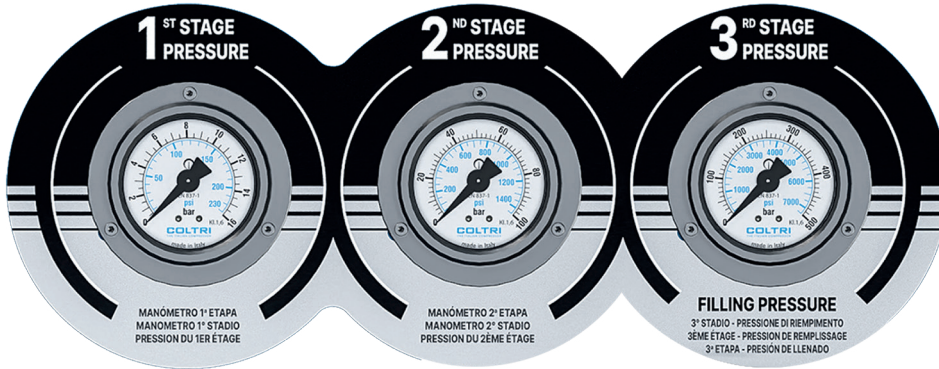

Soundproof frame

Polyether-based expanded polyurethane impregnated with halogen and CFC-free flame retardant substances. Soundproofing useful in any environment that requires a strong reduction of high frequencies.

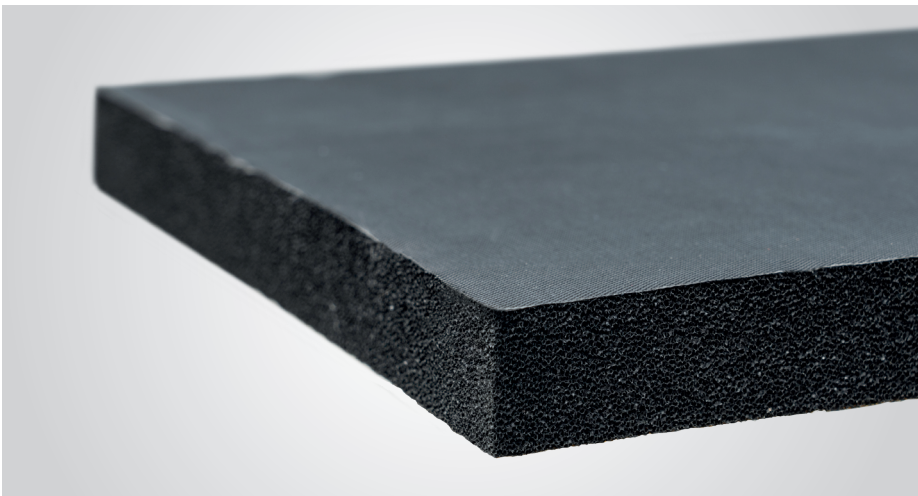



Chemical composition	100% Polyester
Utilisation temperature range	Characteristic maintained in the long term and throughout the whole thickness in the range between - 40° and +110° C. <i>110° C = melting point of the bicomponent fiber shell, temperature of softening beginning of the bicomponent fiber shell = 80° C</i>
Recyclability	100% Recyclable as it does not contain additives or binders apart from polyester.
Massa superficiale	2500 ± 10% g/m ²



Certifications

Color	Black	
Thermal conductivity	W/mk 0,040 40° C	
Temperature resistance	-70° C - 100° C	
Density	75 / 110 Kg/m ³	ISO 1855
Hardness	> 300 N	ISO 2439 (ILD% 40)
Tensile hardness	> 85 Kpa	ISO 1798
Resistance to de-tensioning	> 85 %	ISO 1798
Self-extinguishing	Class 0 / Class 1	BS 476 Part 6 / BS 476 Part 7



Data sheet three-phase electric motor 4 kW

		SPECIFICA TECNICA MOTORE EL. <i>Electric motor technical data sheet</i>		Potenza/ Power (kW)	Poli/ Poles
				4	2
		Data: 25/06/2015		Rev: 0	
No	Descrizione/Description	Dati/Data			U.d.m.
1	Codice Soga / ref. code	125413			
2	Modello / Motor type	MM1 100LC/2			
3	Descrizione / Description	Single-phase motor with starting capacitor 4kW 2 Poles 220V 50Hz			
4	Carcassa motore / Framesize	100L			
5	Poli / Poles	2			
6	Forma di costruzione / Mounting type	IM B3			
7	Potenza nominale / Rated output	4			[kW]
8	Fattore di servizio / Service factor	1.0			
9	Tipo di servizio / Duty type	S1			
10	Tensione / Rated voltage	220			[V]
11	Frequenza / Rated frequency	50			[Hz]
12	Corrente nominale / Rated current	25.2			[A]
13	Velocità nominale / Rated speed	2850			[min ⁻¹]
14	Fattore di potenza / Power factor	0,92			
15	Coppia nominale motore/ Rated motor torque	13,4			[Nm]
17	Corrente avviamento / Corrente nominale Starting current / Rated current	3,9			Isp/In
18	Coppia avviamento / Coppia nominale Starting torque/Rated torque	1,9			Msp/Mn
19	Classe d'isolamento / Insulation class	F			
20	Grado di protezione / Enclosure	IP54			
21	Posizione scatola morsetti (motore con piedini) Terminal box position (motor with feet)	A			
22	Terminali potenza / Power leads terminal	CAVO/ CABLE			
23	Peso / Weight	18			[kg]
24	Cuscinetti /bearings	Drive end	6206		
		Non drive end	6203		
Note/remarks: Motore con condensatore permanente 80µF e disgiuntore elettromeccanico e condensatore di spunto 160µF. Motor with 80µF permanent capacitor and centrifugal switch plus 160µF starting capacitor. Targa con logo Coltri Compressors.					

Data sheet three-phase electric motor 5.5 kW

		SPECIFICA TECNICA MOTORE EL. <i>Electric motor technical data sheet</i>		Potenza/ Power (kW)	Poli/ Poles
				5,5	2
		Data: 24/06/2015		Rev: 0	
No	Descrizione/Description	Dati/Data			U.d.m.
1	Codice Soga / ref. code	124421			
2	Modello / Motor type	MT1 112MB/2			
3	Descrizione / Description	Three-phase asynchronous motor 5.5kW 2 Poles 400/690V 50Hz			
4	Carcassa motore / Framesize	112M			
5	Poli / Poles	2			
6	Forma di costruzione / Mounting type	IM B3			
7	Potenza nominale / Rated output	5,5	5,5	6,5	[kW]
8	Fattore di servizio / Service factor	1.0			
9	Tipo di servizio / Duty type	S3-75%			
10	Tensione / Rated voltage	400/690	400/690	Δ 440-480	[V]
11	Frequenza / Rated frequency	50	60	60	[Hz]
12	Corrente nominale / Rated current	12,6/17,3	12,6/17,3	12,6	[A]
13	Velocità nominale / Rated speed	2850	3420	3420	[min ⁻¹]
14	Fattore di potenza / Power factor	0,86	0,86	0,86	
15	Coppia nominale motore/ Rated motor torque	18,4	15,4	18,2	[Nm]
17	Corrente avviamento / Corrente nominale Starting current / Rated current	7,6			Isp/In
18	Coppia avviamento / Coppia nominale Starting torque/Rated torque	3,1			Msp/Mn
19	Classe d'isolamento / Insulation class	F			
20	Grado di protezione / Enclosure	IP55			
21	Posizione scatola morsetti (motore con piedini) Terminal box position (motor with feet)	A			
22	Terminali potenza / Power leads terminal	M5			
23	Peso / Weight	28			[kg]
24	Cuscinetti /bearings	Drive end	6206		
		Non drive end	6206		
Note/remarks: Targa con logo Soga.					

Data sheet three-phase electric motor 7.5 kW

		SPECIFICA TECNICA MOTORE EL. <i>Electric motor technical data sheet</i>		Potenza/ Power (kW)	Poli/ Poles
				7,5	2
		Data: 16/05/2018		Rev: 0	
No	Descrizione/Description	Dati/Data			U.d.m.
1	Codice Soga / ref. code	186657			
2	Modello / Motor type	MT1 132SB/2			
3	Descrizione / Description	Three-phase asynchronous motor 7.5kW 2 Poles 230/400V 50Hz			
4	Carcassa motore / Framesize	132S			
5	Poli / Poles	2			
6	Forma di costruzione / Mounting type	IM B3			
7	Potenza nominale / Rated output	7,5	7,5	9	[kW]
8	Fattore di servizio / Service factor	1.0			
9	Tipo di servizio / Duty type	S3-75%			
10	Tensione / Rated voltage	230/400	230/400	Δ440-480	[V]
11	Frequenza / Rated frequency	50	60	60	[Hz]
12	Corrente nominale / Rated current	26/15	26/15	15	[A]
13	Velocità nominale / Rated speed	2870	3440	3440	[min ⁻¹]
14	Fattore di potenza / Power factor	0,87	0,87	0,87	
15	Coppia nominale motore/ Rated motor torque	25	20,8	25	[Nm]
17	Corrente avviamento / Corrente nominale Starting current / Rated current	6,9			Isp/In
18	Coppia avviamento / Coppia nominale Starting torque/Rated torque	2,7			Msp/Mn
19	Classe d'isolamento / Insulation class	F			
20	Grado di protezione / Enclosure	IP55			
21	Posizione scatola morsetti (motore con piedini) Terminal box position (motor with feet)	A			
22	Terminali potenza / Power leads terminal	M6			
23	Peso / Weight	42			[kg]
24	Cuscinetti /bearings	Drive end	6208		
		Non drive end	6208		
Note/remarks: Targa con logo Coltri Compressors.					

Optional

Presec. Filter control system

Includes:

Filter cap with sensor + control unit + cartridge.

To be installed with the Hyperfilter filter system filter system on the compressor.

If you choose the Presec system, you cannot also install the the SAM Multigas Analysis System.

The Presec system is connected through a probe with the first filter cartridge and detects its saturation status transmitting to the indicator the relevant switching signals according to the status. If the filter cartridge is exhausted, the compressor is switched off and cannot be started until the cartridge is replaced.

The presec system displays 4 levels of cartridge saturation through 3 relays connected to 3 leds:

Stable green light (a):

- The system is operational; OK cartridge

Yellow light button (b):

- Pre-alarm; cartridge is running low and must be replaced soon.

Red light button (c):

- Alarm; remove cartridge, replace immediately.

Red light button (c):

- Alarm; filter cartridge is missing or filter system is interrupted; compressor shuts down and cannot be turned back on without inserting a new cartridge or discovering the source of the alarm.

While the yellow light is pulsing (b), the steady green light (a) will still be on because the filter cartridge will not be fully saturated.

If no LED lights up, it means that the PRESEC lacks power or that the electrical system is faulty.

Filter saturation values

Light	Humidity (mg/m3)
Green	15 - 20
Yellow	20 - 25
Red	> 25





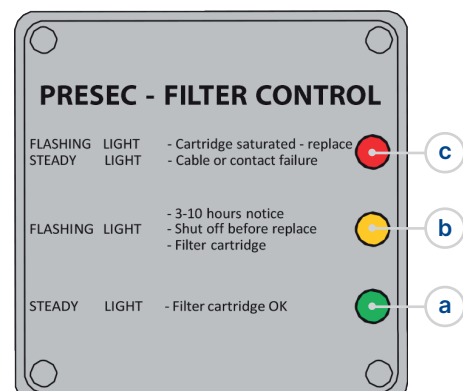





COD. SC000550







C - Monitor

Final filter monitoring system, oil change and technical interface.

The interface consists of an LCD display, a button  and two indicators (, ). The decimal points next to the digits are indicator lights to indicate alarms or warnings in progress. Each dot is associated with an explanatory icon (, , ). The icon  indicates an alarm condition while the symbol  indicates normal operation. Press the button  to scroll through the different functions of the menu. When pressed, the function is displayed the function and after two 2 seconds the related data.



COD. SC001200

- | | | |
|---|--|---|
|  Display |  Service indication |  Operation indicator |
|  Cartridge saturation |  Battery charge level | |

Aerotecnica Coltri S.p.A.

Via dei Colli Storici, 177
25015 Desenzano del Garda
Brescia - Italy

Ph. +39 030 9910301
+39 030 9910297

info@coltri.com



coltri.com

