

Booster line

ASSO VI ZERO LOSS

Electric



CONTACT US

CERTIFICATION: CE UNI EN ISO 9001:2015



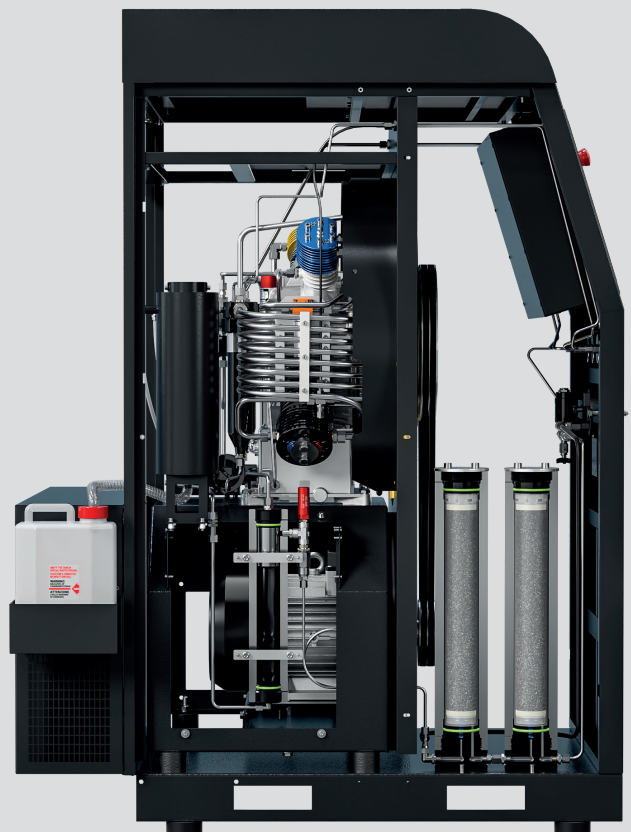
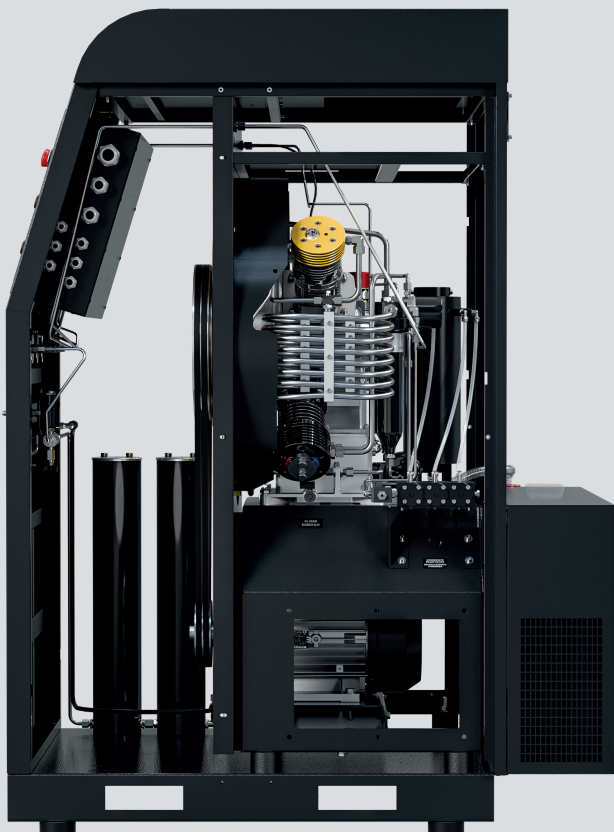
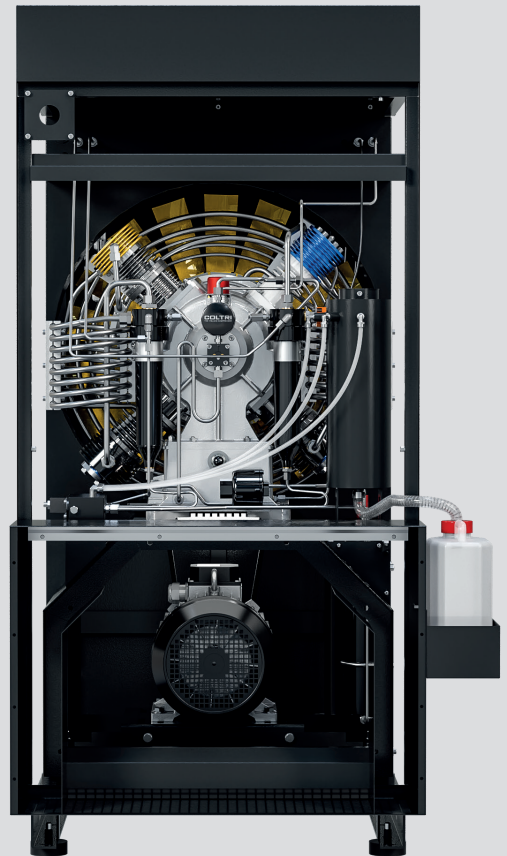

Technical data

Type of gas	Breathing air EN 12021 - Helium - Nitrogen - Argon
Intake pressure	Min. 2 bar Max. 5 bar
Nominal pressure	250 bar / 330 bar
Filling pressure	232 bar / 300 bar
Max working pressure	420 bar
Permissible ambient temperature range	-10° C ÷ +40° C
Permissible altitude	0 ÷ 1.500 m SLM
Max permissible tilt	15°
Design	Soundproof cabinet with sound absorbing
Operating voltage, standard	400 V; 50 Hz
Other operating voltage	230 V, 50 Hz / 440 V, 60 Hz / 230 V, 60 Hz
Oil	Synthetic Coltri Oil ST 755
Oil change interval	Every year / 1.000 h
Frame	Steel 1,5 mm thickness - colour RAL 9005 - Powder coating painting - scratch proof

Compressor

	ASSO VI Zero Loss 11 KW	ASSO VI Zero Loss 15 KW
Flow rate	From 250 l/min to 620 l/min From 15 m ³ /h to 37 m ³ /h	From 280 l/min to 690 l/min From 17 m ³ /h to 41.4 m ³ /h
Purification System	2 Hyperfilter with activated carbon	
Cooling air flow, min.	1.960 m ³ /h	
Weight	373 kg 943 lb	463 kg 1.020 lb
<small>Standard model. Weight and dimensions may vary depending on accessories.</small>		
Dimensions (W x D x H)	93,5 × 130,2 × 173,5 cm - 36.8 × 51.3 × 68.3 in	

Motor

	ASSO VI Zero Loss 11 KW	ASSO VI Zero Loss 15 KW
Power	11 kW, 15 Hp	15 kW, 20 Hp
Type	Three-phase electric	
Operating voltage/frequency	400 V, 50 Hz	
<small>Different voltage / frequency available on request.</small>		
Rated current	23 A	31 A
Speed (RPM)	2.910 1/min	2.920 1/min
Protection class	IP55 (TEFC)	

Dimensions

Width 93,5 cm (36.8")
Depth 130,2 cm (51.3")
Height 173,5 cm (68.3")

Dry weight

ASSO VI Zero Loss 11 KW
373 kg (943 lb)
ASSO VI Zero Loss 15 KW
463 kg (1.020 lb)

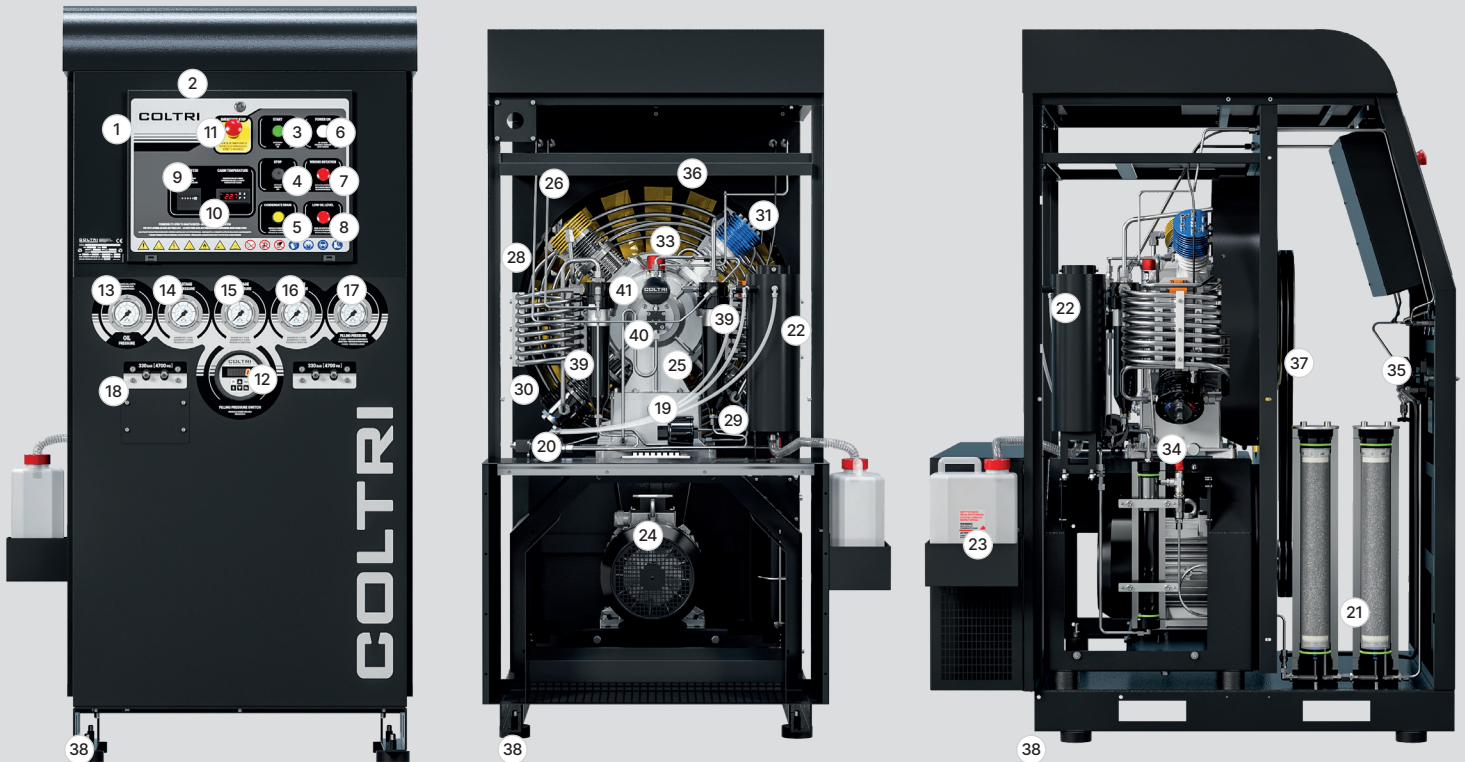

Machine parts

- | | | | | | |
|----|--|----|---|----|----------------------------------|
| 1 | Frame | 14 | 1st stage pressure gauge | 28 | 1st stage gas recovery |
| 2 | Control panel | 15 | 2nd stage pressure gauge | 29 | 2nd stage |
| 3 | ON pushbutton | 16 | 3rd stage pressure gauge | 30 | 3rd stage |
| 4 | Stop pushbutton | 17 | 4th stage pressure gauge / working pressure | 31 | 4th stage |
| 5 | Condensate discharge pushbutton | 18 | Pressure gas outlet | 32 | Condensate discharge valves |
| 6 | Power indicator light | 19 | Oil level | 33 | Oil filler plug |
| 7 | Direction of rotation indicator light | 20 | Oil discharge valves | 34 | Safety valve |
| 8 | Oil level warning light | 21 | Purification system | 35 | Pressure maintenance valve |
| 9 | Hour counter | 22 | Condensate collection container | 36 | Cooling fan |
| 10 | Cabinet interior / cooling air temperature | 23 | Condensate collection tank | 37 | Belt |
| 11 | Emergency pushbutton | 24 | Electric motor | 38 | Final condensate separator |
| 12 | Automatic shut off pressure switch | 25 | Pumping unit | 39 | Oil pump |
| 13 | Oil pressure gauge | 26 | Gas inlet 2÷5 bar | 40 | Oil filter |
| | | 27 | Condensate separator | 41 | Circuit pressure discharge valve |

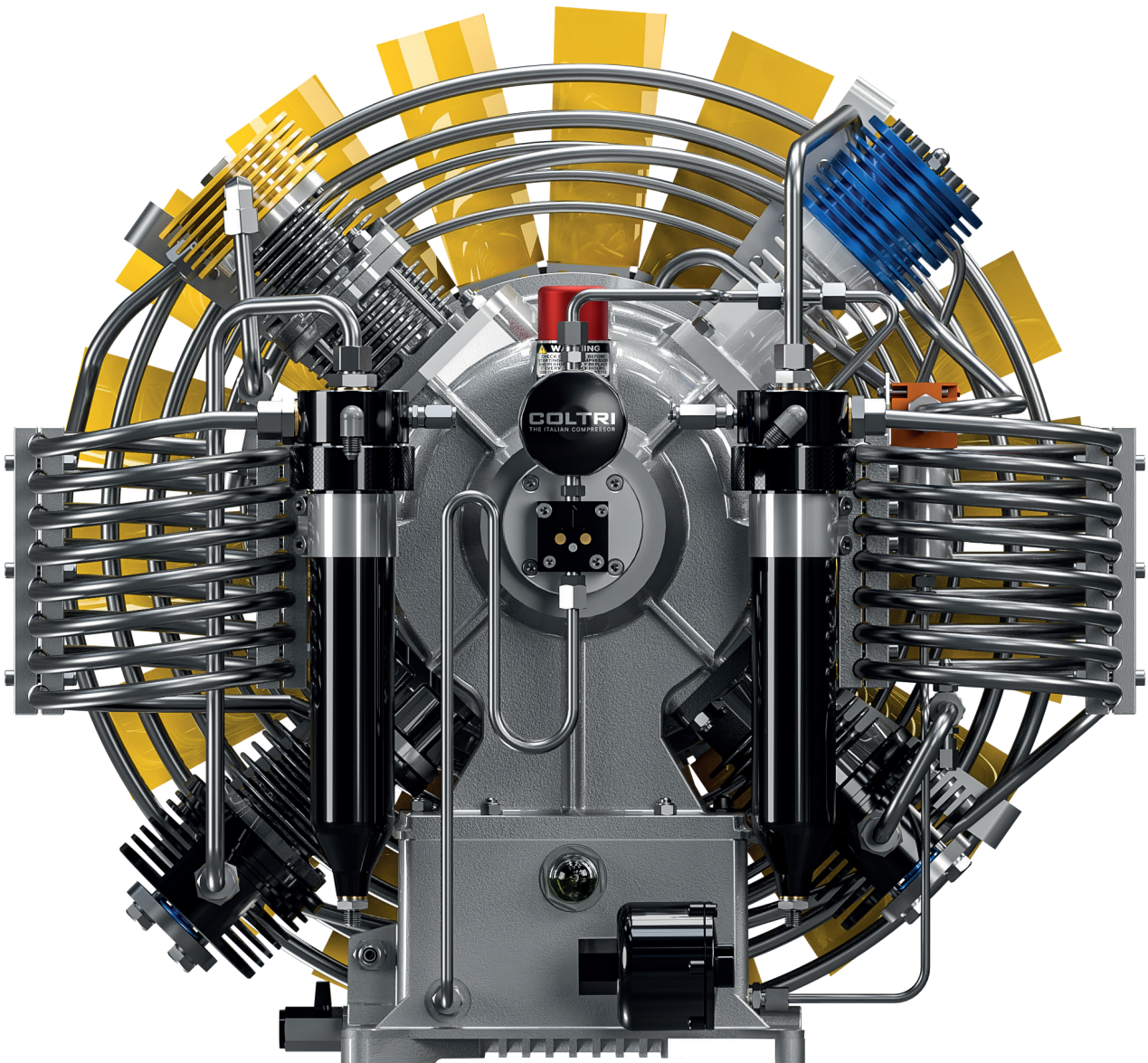

1. Forced lubrication with low pressure gear pump



2. First stage for gas recovery

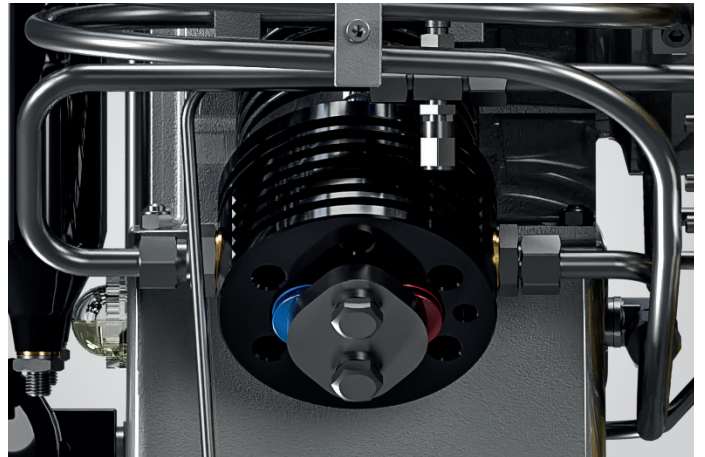

3. Pipes, fittings and nuts in stainless steel AISI 316

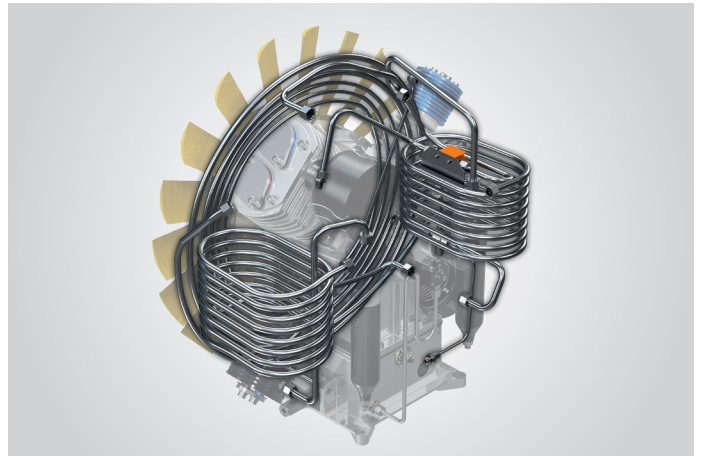

4. Synthetic oil with special formulation for HP compressors Heavy Duty



Discover more on Coltri Oil ST 755

5. Intermediate condensate separator after the second stage

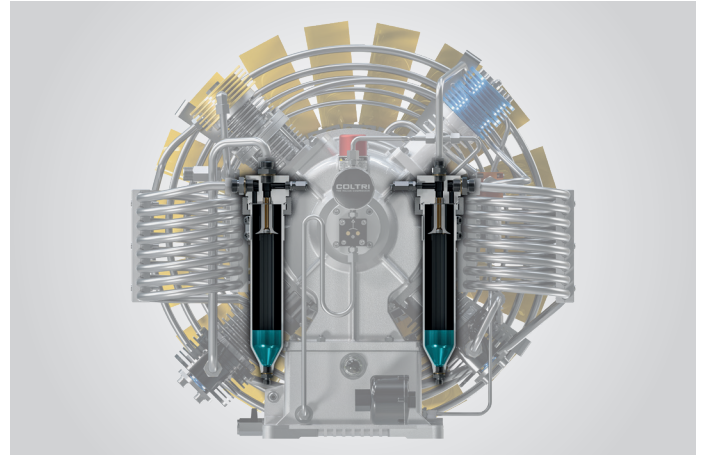

6. High pressure final condensate separators double effect

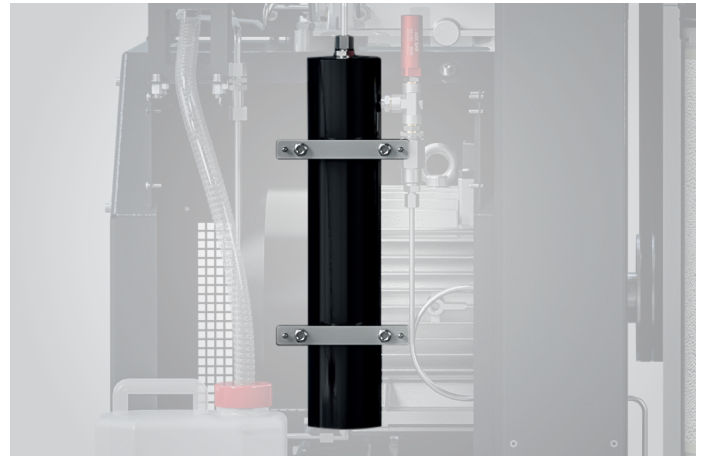

7. Safety valves after each stage of compression

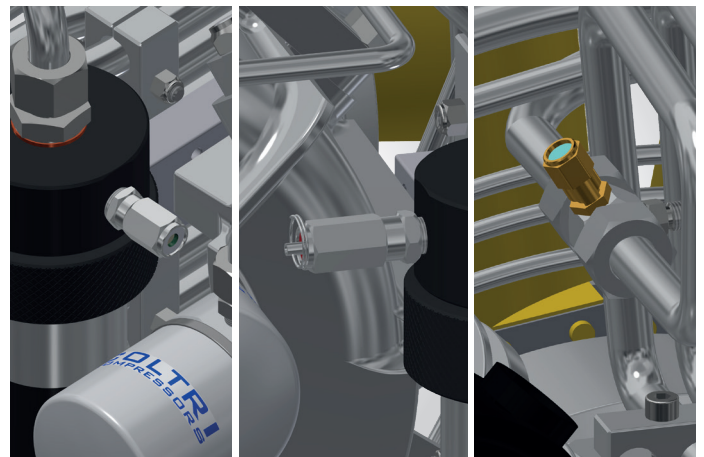

8. Special cast iron cylinders with low roughness lapping



9. Forged aluminum connecting rods



10. Forged steel crankshaft

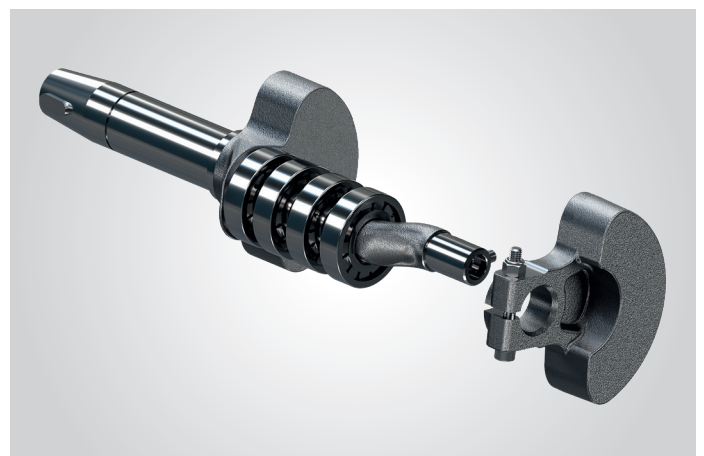

11. High-flow first, second and third stage valves

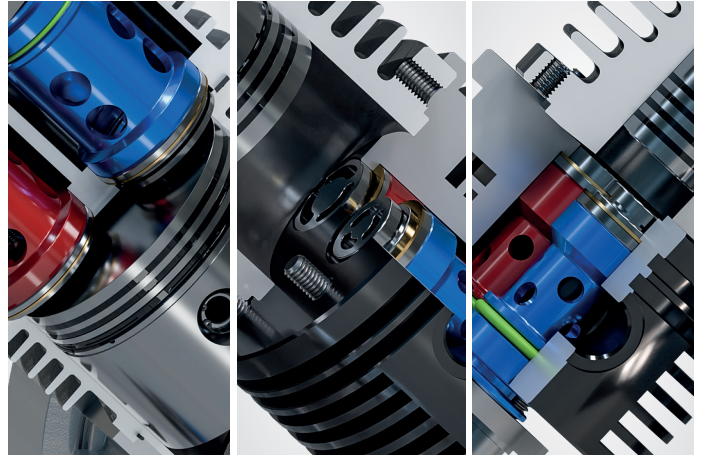

12. Roller Bearings for intensive work

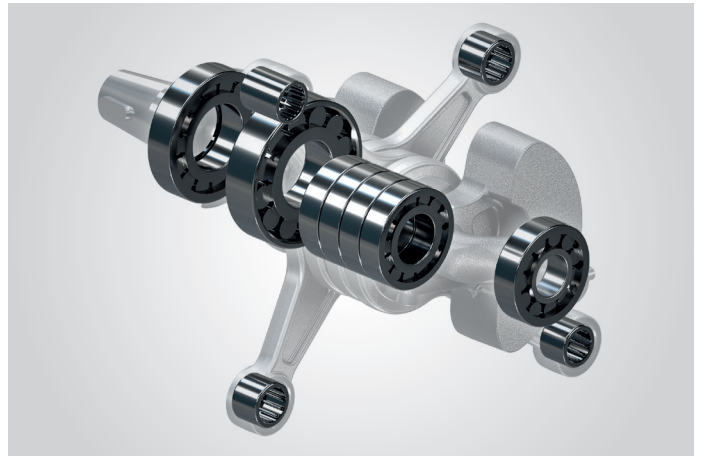

13. Fourth stage in tempered steel with 6 piston rings in special cast iron

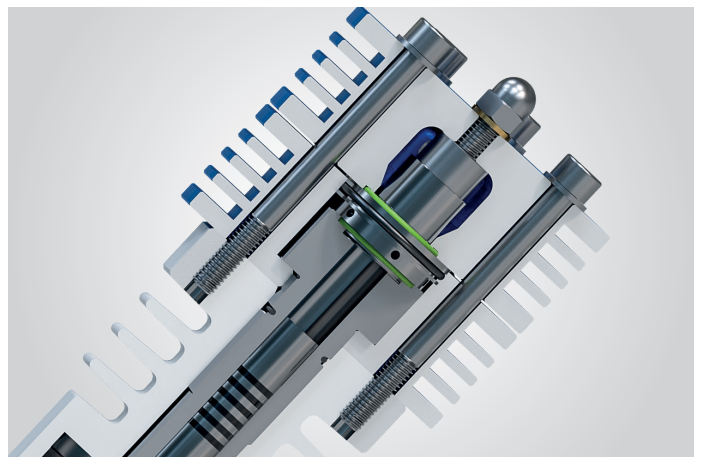

14.
 Second and third stage
 with pushing pistons
 to eliminate lateral forces
 on the pistons

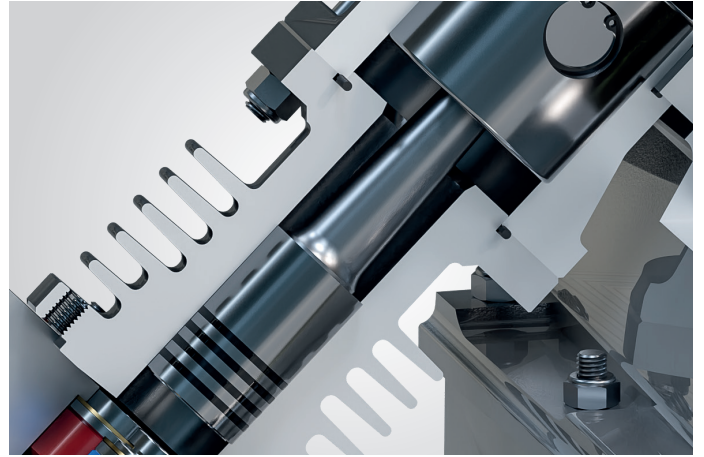

15.
 CE certification

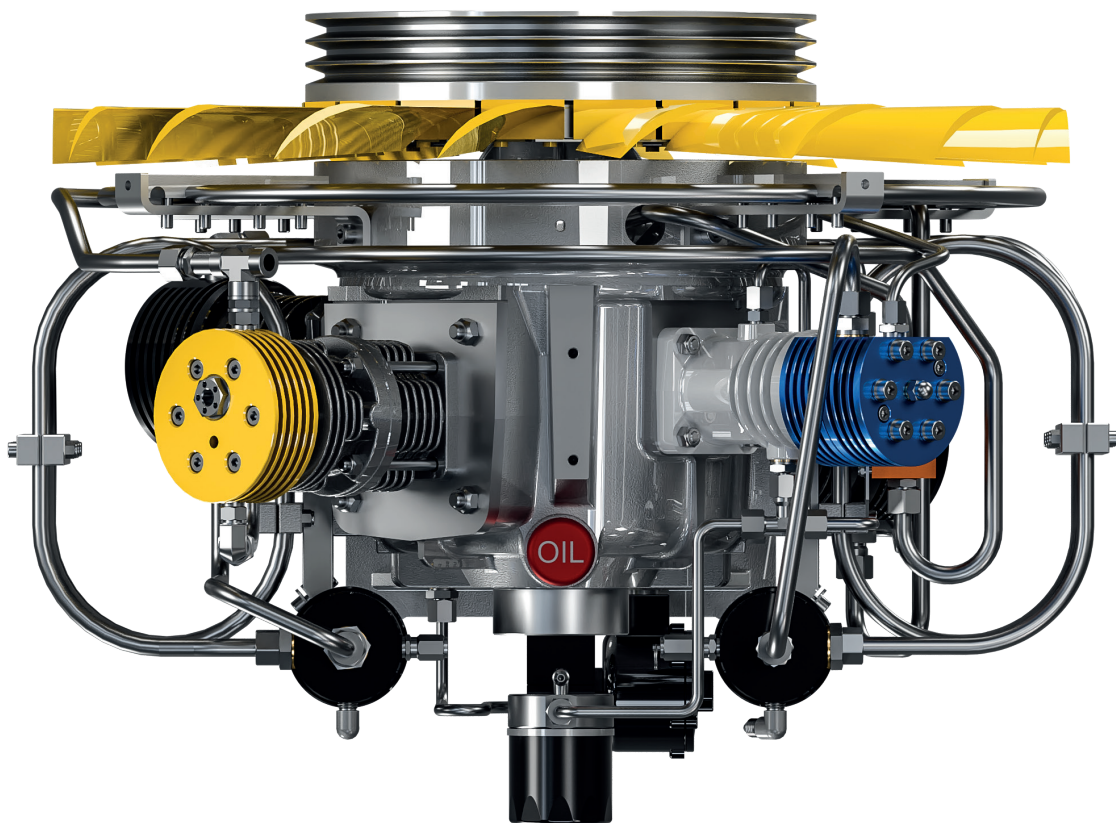

Compressor block

ASSO VI Zero Loss 11 KW

ASSO VI Zero Loss 15 KW

Intake pressure	2 bar - 5 bar	
Flow rate	From 250 l/min to 620 l/min From 15 m ³ /h to 37 m ³ /h	From 280 l/min to 690 l/min From 17 m ³ /h to 41.4 m ³ /h
Speed RPM	1.250 1/min	1.400 1/min
Number of stages	3 + 1 service	
Number of cylinders	3 + 1 service	
Cylinder bore 2nd stage	60 mm	
Cylinder bore 3rd stage	32 mm	
Cylinder bore 4th stage	15 mm	
Stroke	50 mm	
Direction of rotation (from flywheel side)	Left - counter clockwise	
Drive type	V-belt A type	
Amount of oil	4 liters	

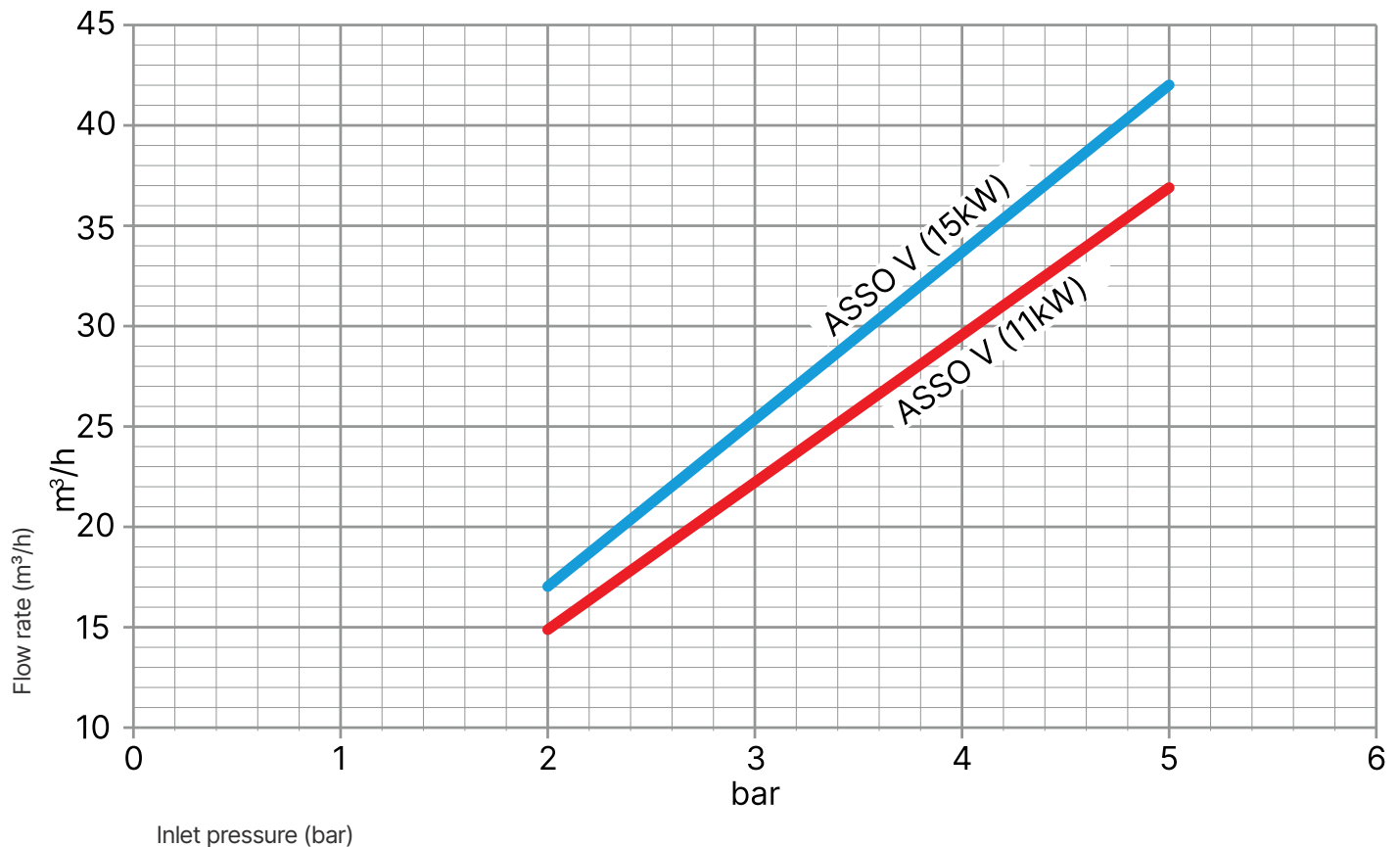

Standard equipment

Purification system HYPERFILTER

DOUBLE HYPERFILTER regenerable or disposable cartridge



- ① HYPERFILTER body
- ② Upper cap
- ③ O-Ring
- ④ Cartridge spring
- ⑤ HYPERFILTER cartridge
- ⑥ Fitting
- ⑦ Lower cap
- ⑧ Stainless hook
- ⑨ Upper cap
- ⑩ Felt disc
- ⑪ Network Disc

Purification system

Operating pressure (Standard)

Hyperfilter x 2

250 bar / 330 bar / 360 bar

Operating pressure max. (PS)

420 bar

Processable air capacity
(air inlet temperature in the filter 20° C at 300 bar)¹

3.050 m³

¹ When using a filter cartridge without HOPCALITE CO CATALYST.

When using a cartridge with CO-removal, the processable air capacity is reduced by ca. 20%.

Separator system

- Interstage separator after 2nd stage, forged and anodized aluminum.
- Double final separator for removal of oil/water condensate
- Final safety valve, mounted on the separator housing
- Pressure maintenance valve / non-return valve

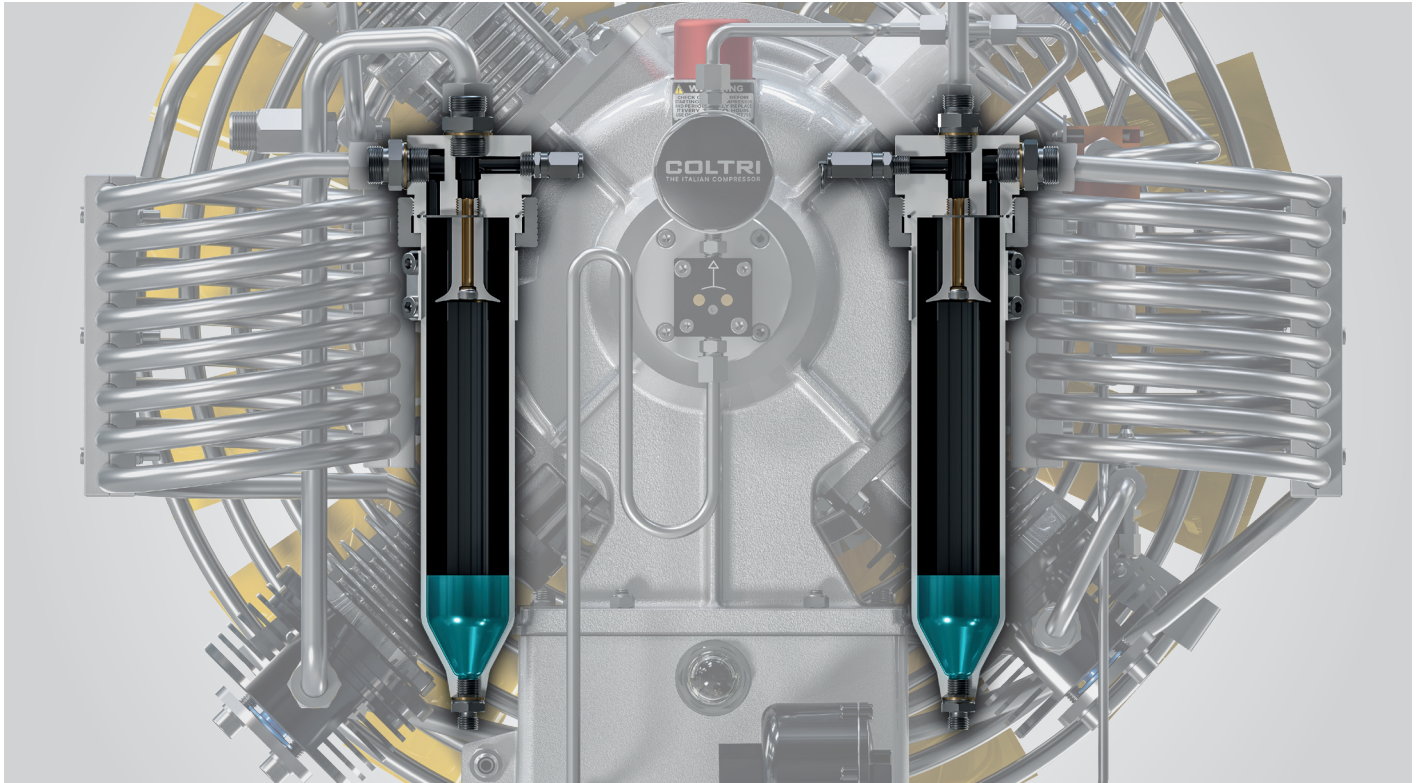

Contamination	Maximum content as per DIN EN 12021:2014	Air quality*
H ₂ O	25 mg/m ³	≤ 10 mg/m ³
CO	5 ppm(v)	≤ 4
CO ₂	500 ppm(v)	≤ 500
Oil	0,5 mg/m ³	≤ 0,5 mg/m ³

* Measured at our facility using ASCO HORA 160 ANALYZER.

1 Only with special filter cartridge with HOPCALITE CO CATALYST. and up to a maximum concentration of 25 ppm CO in intake air.

The compressed clean breathing air then contains a maximum of 5 ppm CO.

2 The level of CO₂ in the intake air must not exceed the maximum level of CO₂ as per EN 12021:2014

3 Reported values exceed ISO 8573-1 standards.

Filling connections

2 Filling connection to choose from: DRV DIN 232 bar and DRV DIN 300 bar.



Filling connection DRV DIN 232 bar
COD. DRV232

Filling connection DRV DIN 300 bar
COD. DRV300

Filling device	DRV DIN 232	DRV DIN 300
Nominal pressure (PN)	250 bar	330 bar
Valve design	Filling valve with integrated ventilation, with cylinder connector G 5/8" according to EN 144-2 and 477 PN232	Filling valve with integrated ventilation, with cylinder connector G 5/8" according to EN 144-2 and 477 PN232

Filling hose

1200 mm stainless steel fittings - max working pressure 420 bar



Electronic pressure switch

The instrument allows to visualize the pressure expressed in bar, psi or MPa.

Through the programming buttons it allows to set the intervention pressure of the relay contact (SPDT) and hysteresis. The settings are protected by passwords at 3 levels: manufacturer, customer and end user. The instrument also has the function of hours counter and no. of cycles of separator intervention, ensuring a general improvement of the operation of the recharge station over time and the longevity of its filters.



According to EN 10204 Type 2.1

N.	Caratteristiche / Characteristics	Valori richiesti / requested values	Tolleranze / Tolerances	Strumento di controllo / Test equipment	Esito verifiche / Test Result
1	Setpoint alarm	300 bar	err.max 1,5% vfs	Elect. load 16V/10mA max	OK
2	Setpoint hysteresis	10 bar	err.max 1,5% vfs	Elect. load 16V/10mA max	OK
3	Range	0 – 400 bar	err.max 1,5% vfs	Pressure gauge cl. 0,25% vfs	OK
4	Process connection	G1/4"	Tab ISO228	Ring ISO228	OK

Compressor control and automatic condensate drain system

- ON/OFF switch with motor protection switch.
- Optional: autostart at 60 bar hysteresis.
- Transformer.
- Pressure switch stops compressor at final pressure.
- Drainage of all separators between the individual stages and also of the final separator during compressor operation (standard drain interval every 15 minutes for a period of 6 seconds).
- Timer for automatic condensate drainage device.
- Integrated vacuum start-up (automatic drain when the unit is switched off).
- Condensate collection tank 5 liters, with silencer; capacity approx. 3 liters, for environmentally friendly disposal of condensate.
- Interstage pressure gauges display the operating pressure for the individual compression stages. This pressure information allows you to check the tightness of the valves (inlet and outlet) of each stage and quickly identify potential sources of failure.

The interstage pressure gauges are mounted in the compressor frame.

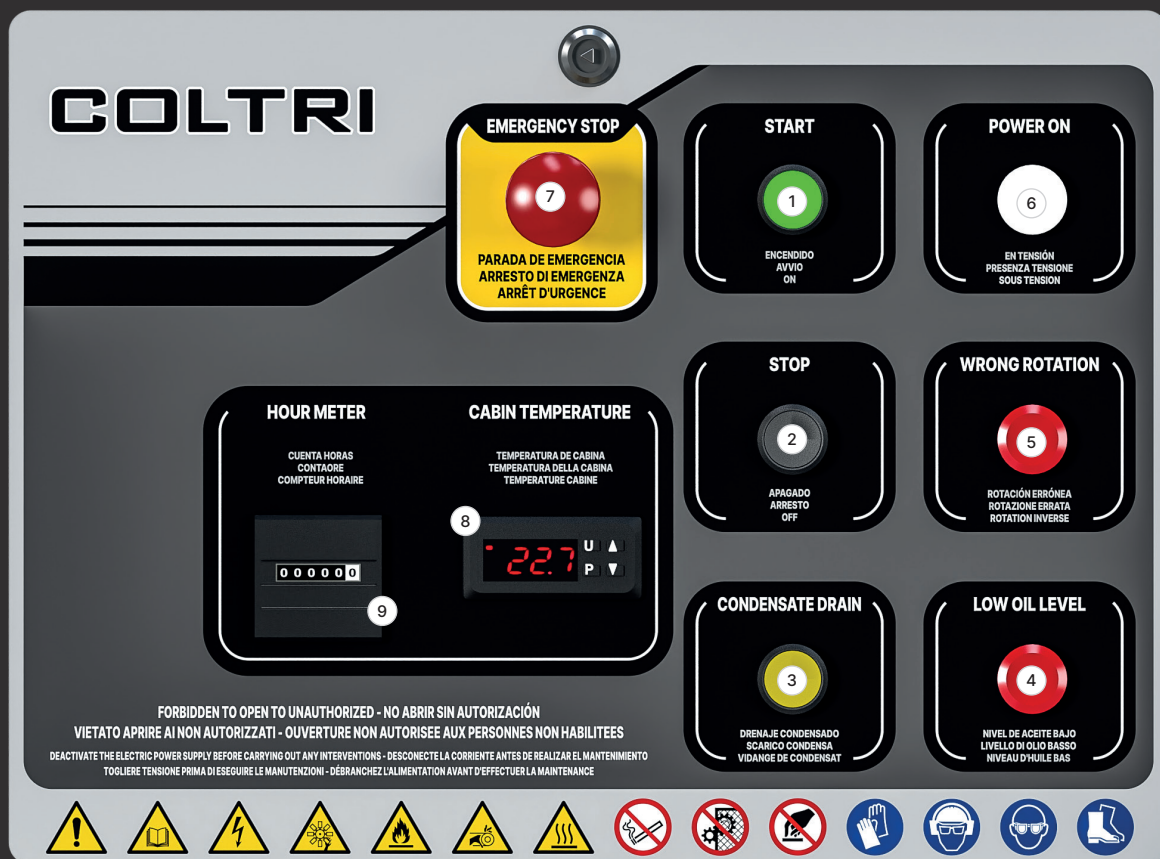

- | | | |
|---------------------------|------------------------------------|---------------------------------------|
| ① Power button | ④ Oil level warning light | ⑦ Emergency button |
| ② Stop button | ⑤ Wrong direction indicator light | ⑧ Inside temperature cabin/cooled air |
| ③ Condensate drain button | ⑥ Voltage presence indicator light | ⑨ Operating hour meter |

Optional

Presec. Filter control system

Includes:

Filter cap with sensor + control unit + cartridge.

To be installed with the Hyperfilter filter system filter system on the compressor.

If you choose the Presec system, you cannot also install the the SAM Multigas Analysis System.

The Presec system is connected through a probe with the first filter cartridge and detects its saturation status transmitting to the indicator the relevant switching signals according to the status. If the filter cartridge is exhausted, the compressor is switched off and cannot be started until the cartridge is replaced.

The presec system displays 4 levels of cartridge saturation through 3 relays connected to 3 leds:

Stable green light (a):

- The system is operational; OK cartridge

Yellow light button (b):

- Pre-alarm; cartridge is running low and must be replaced soon.

Red light button (c):

- Alarm; remove cartridge, replace immediately.

Red light button (c):

- Alarm; filter cartridge is missing or filter system is interrupted; compressor shuts down and cannot be turned back on without inserting a new cartridge or discovering the source of the alarm.

While the yellow light is pulsing (b), the steady green light (a) will still be on because the filter cartridge will not be fully saturated.

If no LED lights up, it means that the PRESEC lacks power or that the electrical system is faulty.

Filter saturation values

Light	Humidity (mg/m3)
Green	15 - 20
Yellow	20 - 25
Red	> 25





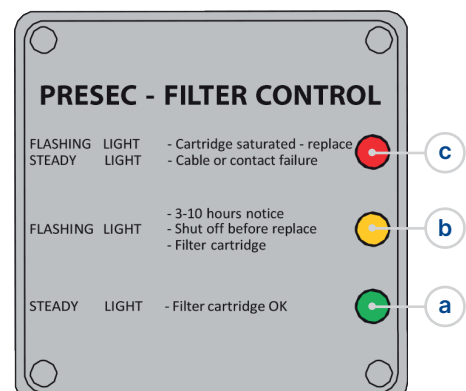





COD. SC000550



Optional





C - Monitor

Final filter monitoring system, oil change and technical interface.



The interface consists of an LCD display, a button  and two indicators (, ). The decimal points next to the digits are indicator lights to indicate alarms or warnings in progress. Each dot is associated with an explanatory icon (, , ). The icon  indicates an alarm condition while the symbol  indicates normal operation. Press the button  to scroll through the different functions of the menu. When pressed, the function is displayed the function and after two 2 seconds the related data.





COD. SC001200

- | | | |
|---|--|---|
|  Display |  Service indication |  Operation indicator |
|  Cartridge saturation |  Battery charge level | |

Data sheet three-phase electric motor 11 kW

		SPECIFICA TECNICA MOTORE EL. <i>Electric motor technical data sheet</i>		Potenza/ Power (kW)	Poli/ Poles
				11	2
				Data 25/06/2015	Rev. 0
No	Descrizione/Description	Dati/Data			U.d.m.
1	Codice Soga / ref.code	150784			
2	Modello / Motor type	MT1 132MC/2			
3	Descrizione / Description	Three-phase asynchronous motor 11kW 2 Poles 400/690V 50Hz			
4	Carcassa motore / Framesize	132M			
5	Poli / Poles	2			
6	Forma di costruzione / Mounting type	IM B3			
7	Potenza nominale / Rated output	11	11	13	[kW]
8	Fattore di servizio / Service factor	1.0			
9	Tipo di servizio / Duty type	S3-75%			
10	Tensione / Rated voltage	230/400	230/400	440-480V	[V]
11	Frequenza / Rated frequency	50	60	60	[Hz]
12	Corrente nominale / Rated current	39,8/23	36,5/21,1	23	[A]
13	Velocità nominale / Rated speed	2910	3500	3500	[min ⁻¹]
14	Fattore di potenza / Power factor	0,87	0,91	0,87	
15	Coppia nominale motore / Rated motor torque	36,1	30	35,5	[Nm]
17	Corrente avviamento / Corrente nominale Starting current / Rated current	6,8			Isp/In
18	Coppia avviamento / Coppia nominale Starting torque/Rated torque	2,7			Msp/Mn
19	Classe d'isolamento / Insulation class	F			
20	Grado di protezione / Enclosure	IP55			
21	Posizione scatola morsettiera (motore con piedini) Terminal box position (motor with feet)	 A			
22	Terminali potenza / Power leads terminal	M6			
23	Peso / Weight	51			[kg]
24	Cuscinetti /bearings	Drive end	6308		
		Non drive end	6308		
Note/remarks: Targa con logo Coltri Compressors.					

Data sheet three-phase electric motor 15 kW

		SPECIFICA TECNICA MOTORE EL. <i>Electric motor technical data sheet</i>		Potenza/ Power (kW)	Poli/ Poles
				15	2
				Data 25/06/2015	Rev. 0
No	Descrizione/Description	Dati/Data			U.d.m.
1	Codice Soga / ref.code	150790			
2	Modello / Motor type	MT1 132MD/2			
3	Descrizione / Description	Three-phase asynchronous motor 15kW 2 Poles 230/400V 50Hz			
4	Carcassa motore / Framesize	132M			
5	Poli / Poles	2			
6	Forma di costruzione / Mounting type	IM B3			
7	Potenza nominale / Rated output	15	15	18	[kW]
8	Fattore di servizio / Service factor	1.0			
9	Tipo di servizio / Duty type	S3-75%			
10	Tensione / Rated voltage	230/400	230/400	440-480V	[V]
11	Frequenza / Rated frequency	50	60	60	[Hz]
12	Corrente nominale / Rated current	53,7/31	53,7/31	31	[A]
13	Velocità nominale / Rated speed	2920	3500	3500	[min ⁻¹]
14	Fattore di potenza / Power factor	0,86	0,91	0,86	
15	Coppia nominale motore / Rated motor torque	49	41	49,1	[Nm]
17	Corrente avviamento / Corrente nominale Starting current / Rated current	7,2			Isp/In
18	Coppia avviamento / Coppia nominale Starting torque/Rated torque	2,5			Msp/Mn
19	Classe d'isolamento / Insulation class	F			
20	Grado di protezione / Enclosure	IP55			
21	Posizione scatola morsettiera (motore con piedini) Terminal box position (motor with feet)	 A			
22	Terminali potenza / Power leads terminal	M6			
23	Peso / Weight	59			[kg]
24	Cuscinetti /bearings	Drive end	6308		
		Non drive end	6308		
Note/remarks: Targa con logo Coltri Compressors.					

Aerotecnica Coltri S.p.A.

Via dei Colli Storici, 177
25015 Desenzano del Garda
Brescia - Italy

Ph. +39 030 9910301
+39 030 9910297

info@coltri.com



coltri.com

